

Ringwood 34mm

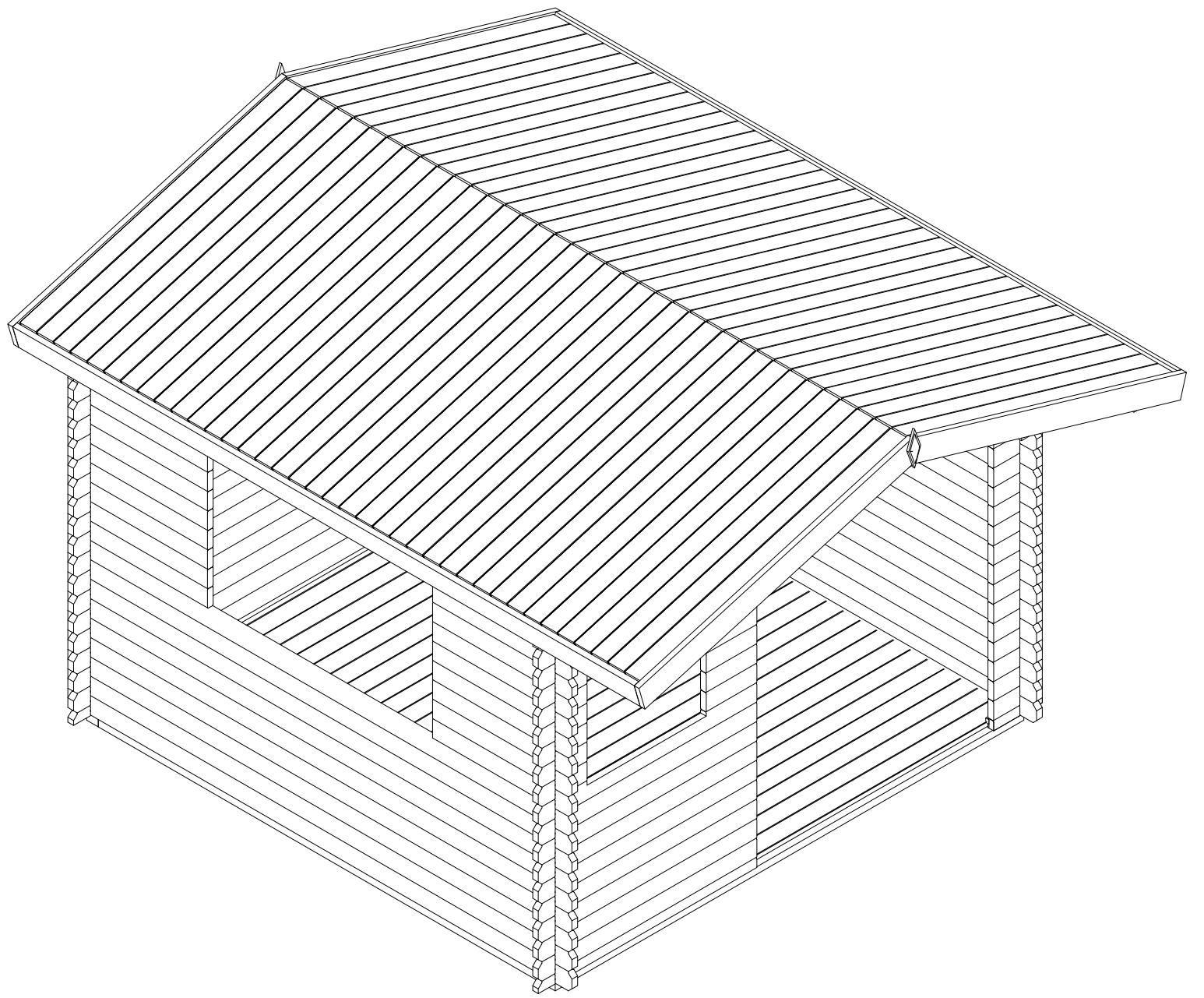

Ringwood 34mm

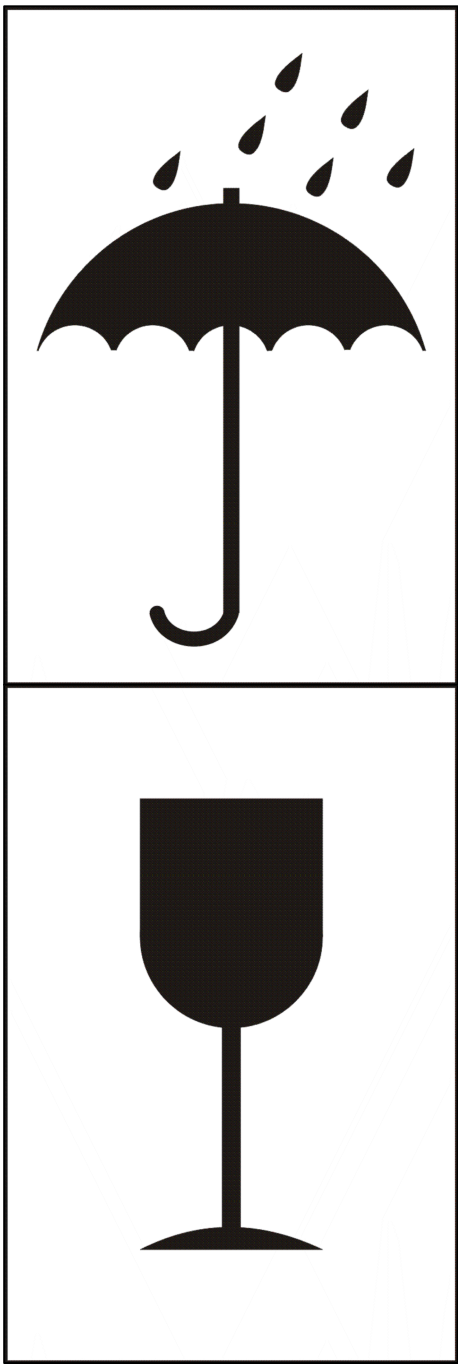
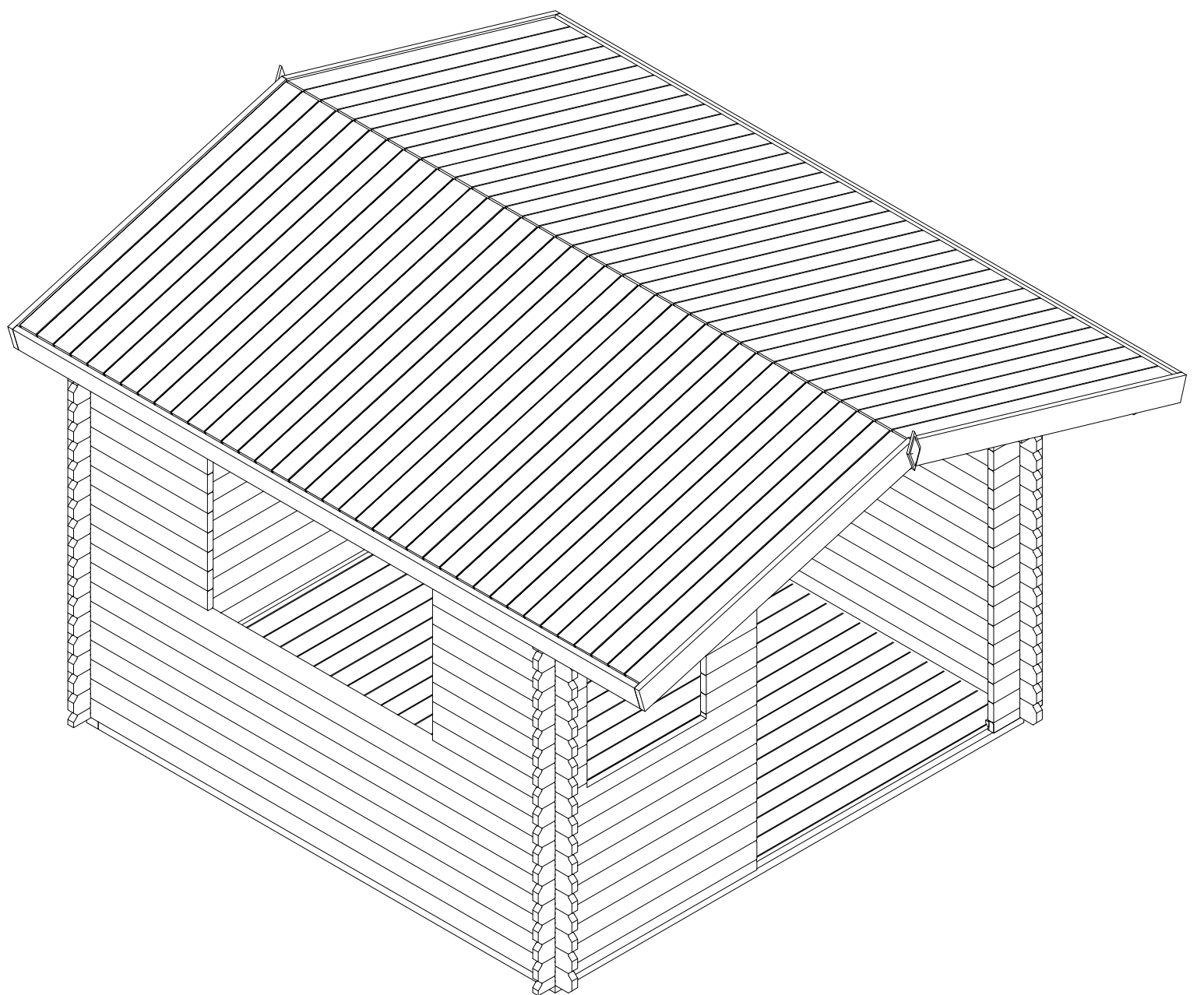
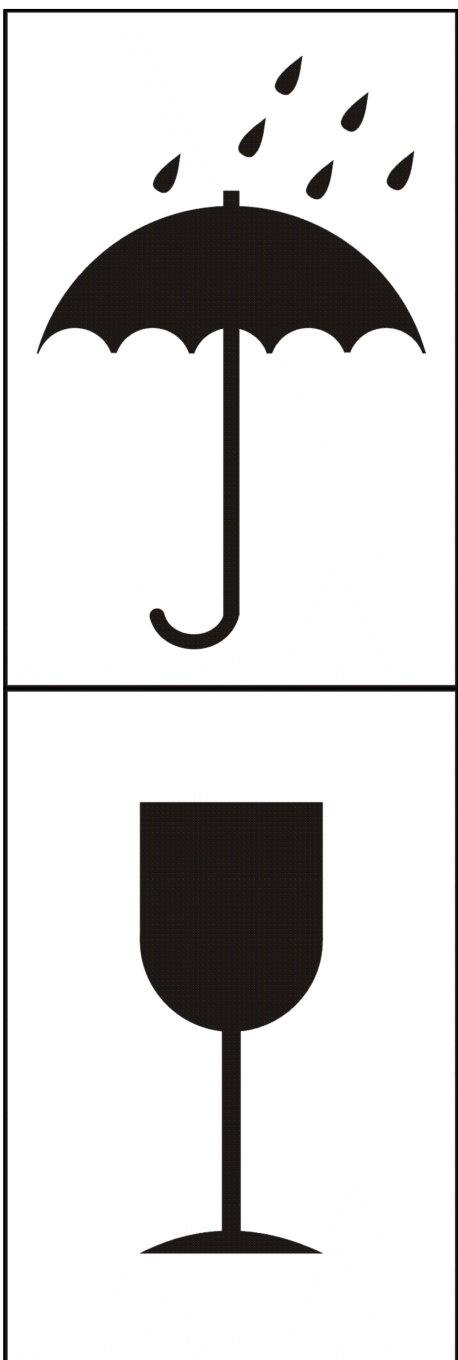

Ringwood 34mm

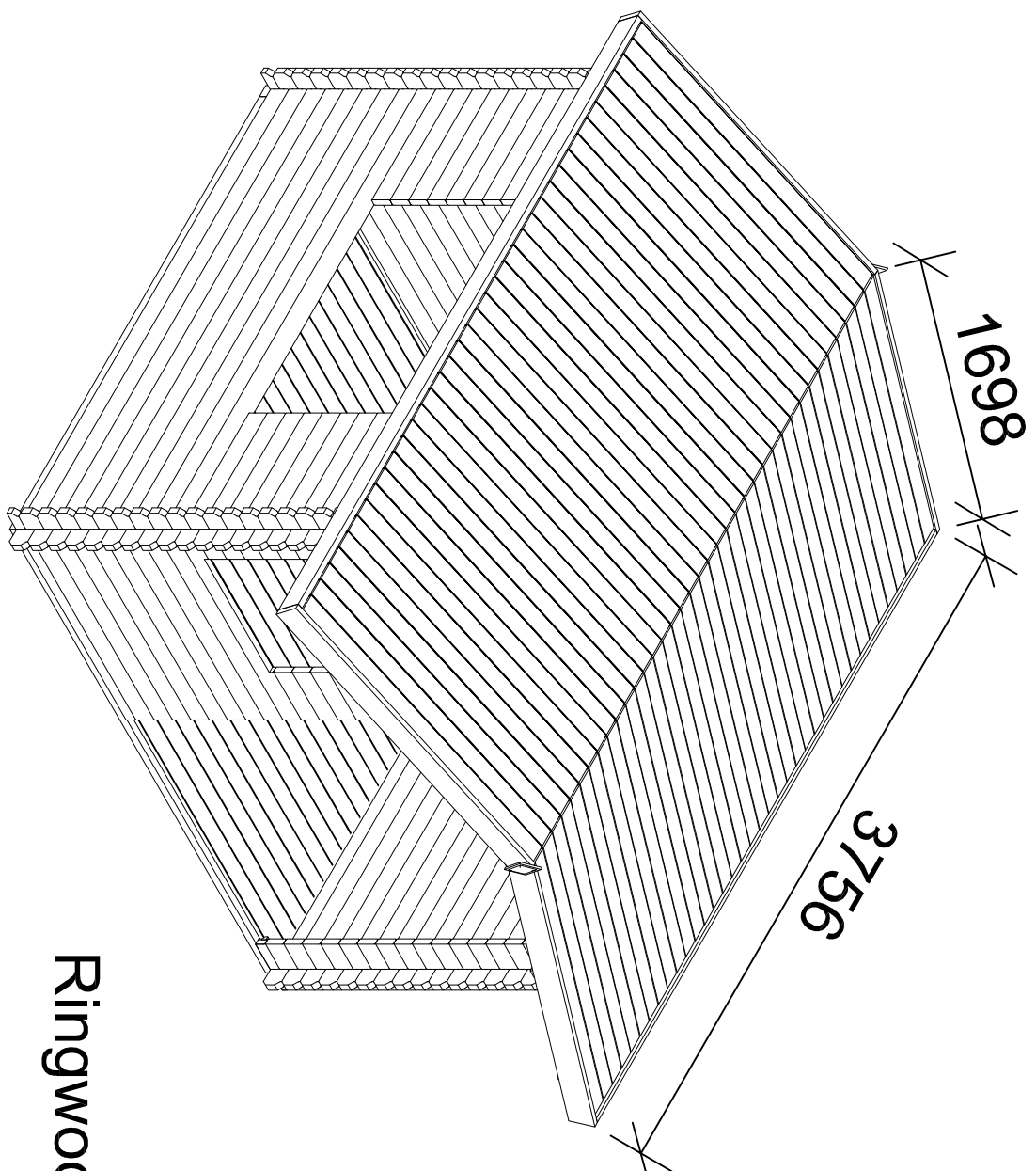

Ringwood 34mm

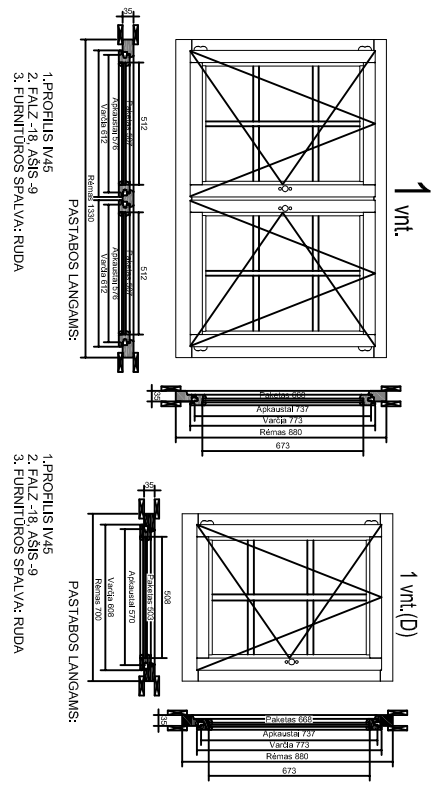
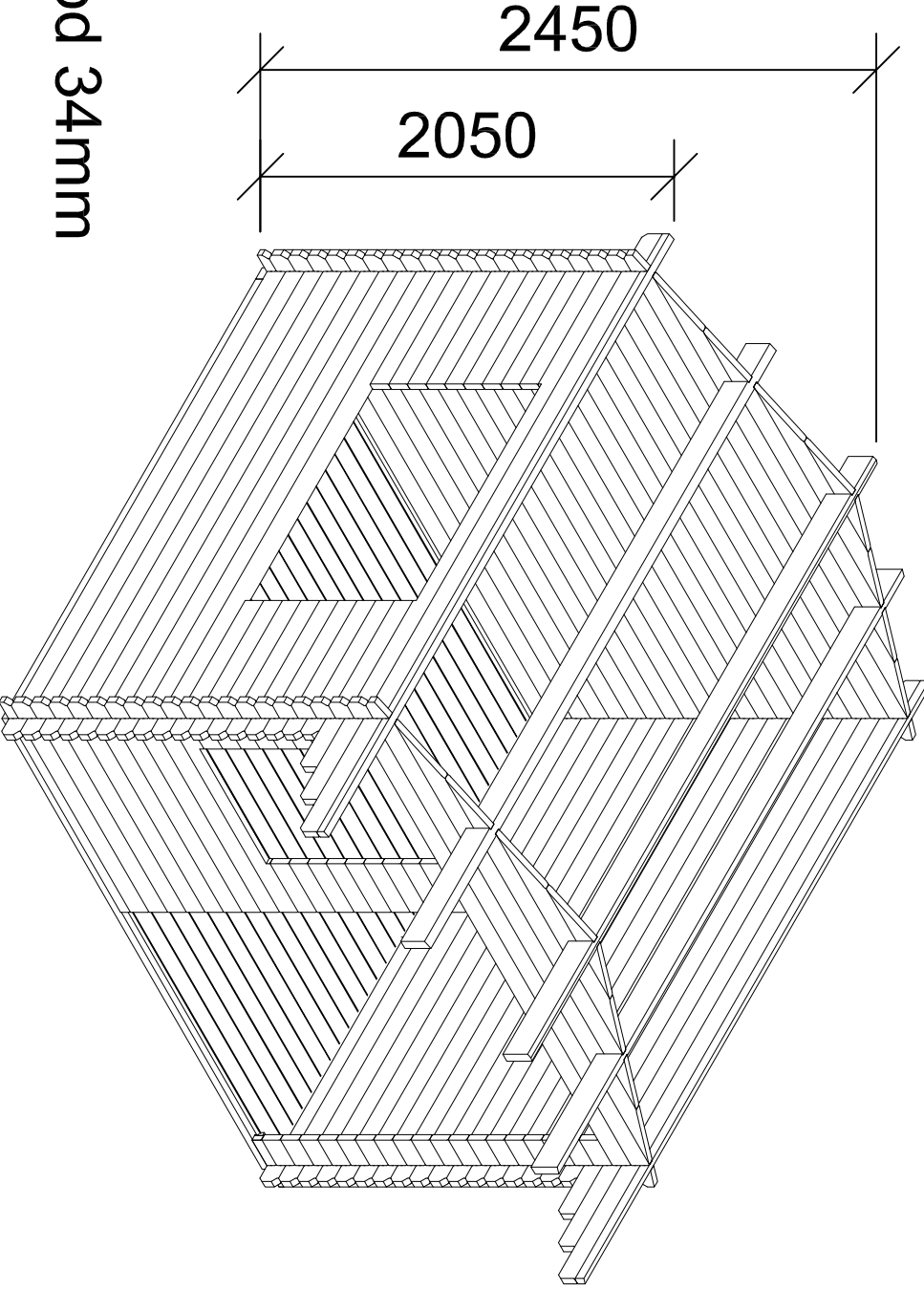

Ringwood 34mm

su frezavimais vyriams

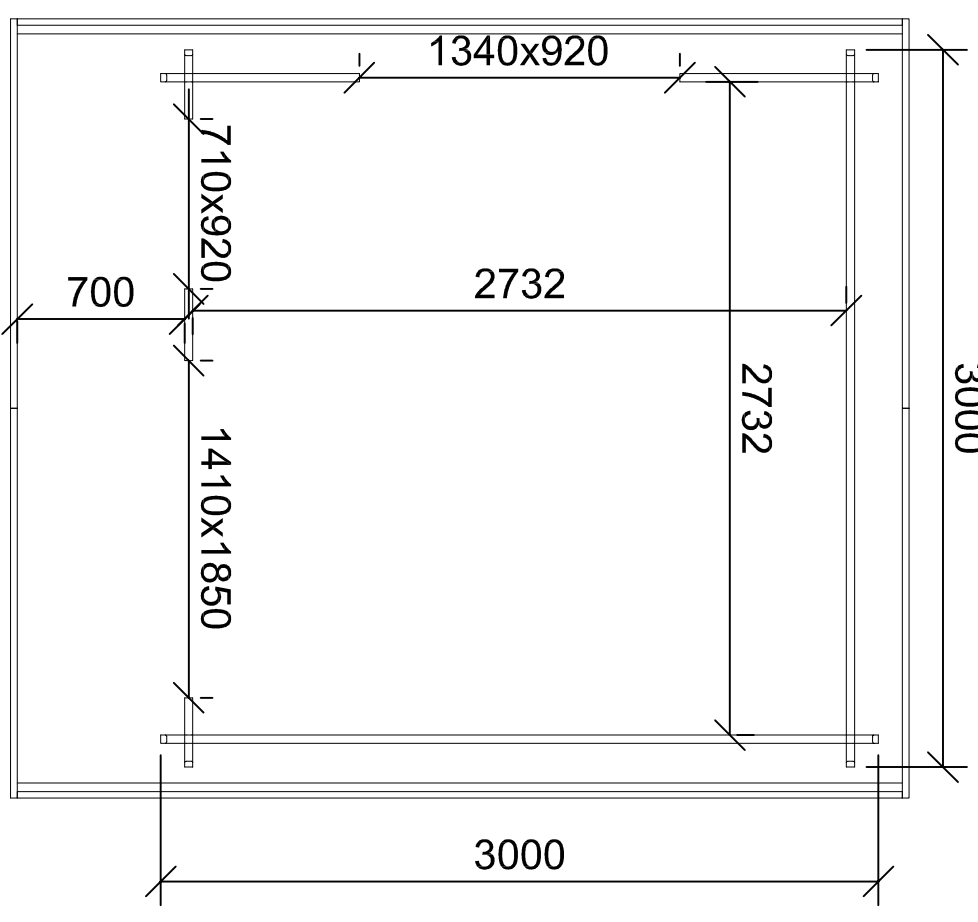
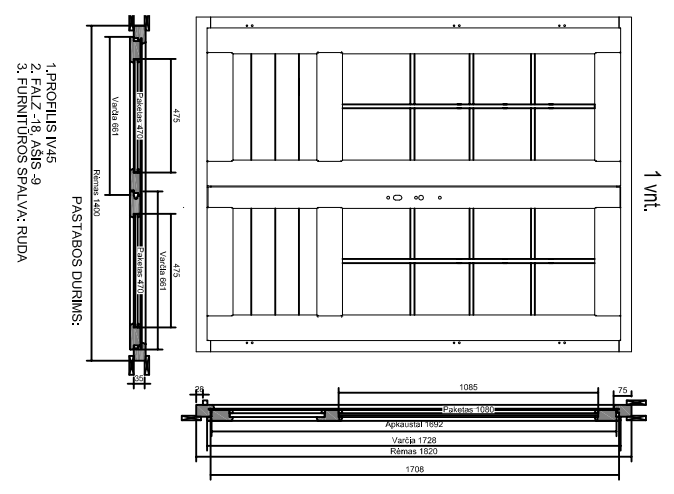

Ringwood 34mm

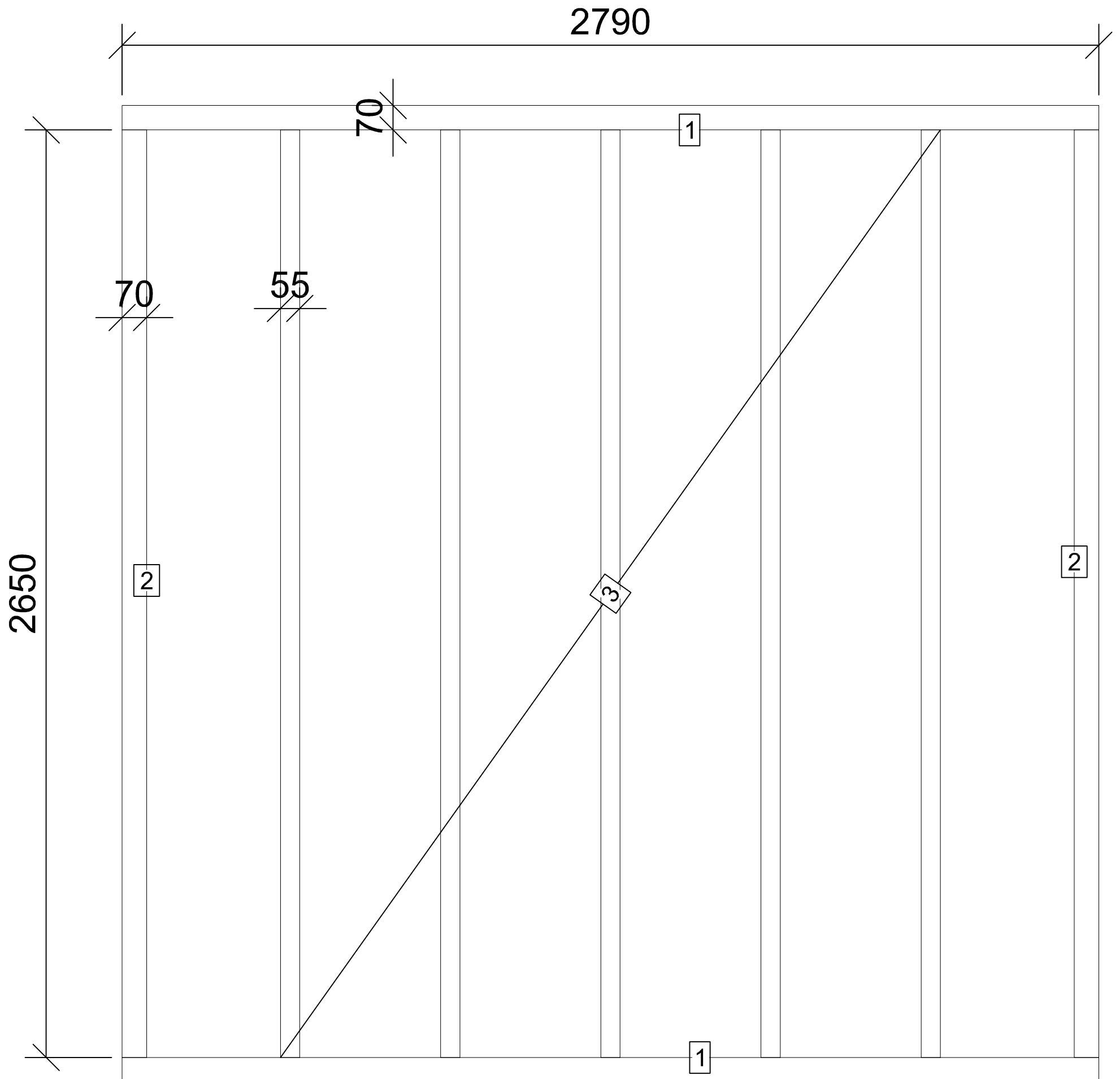

Ringwood 34mm

2722

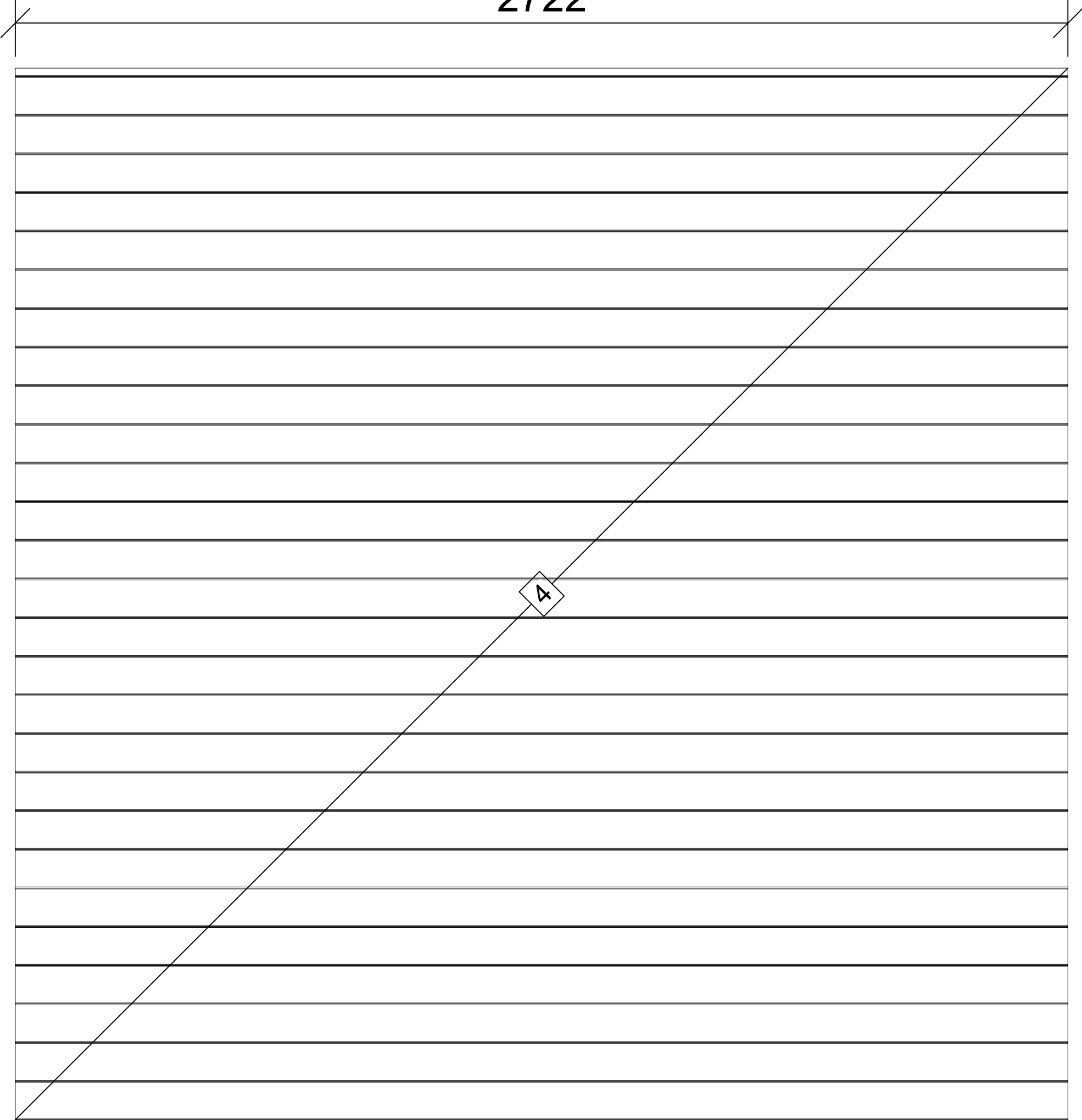

5 pos. ~ 11 meters

Ringwood 34mm

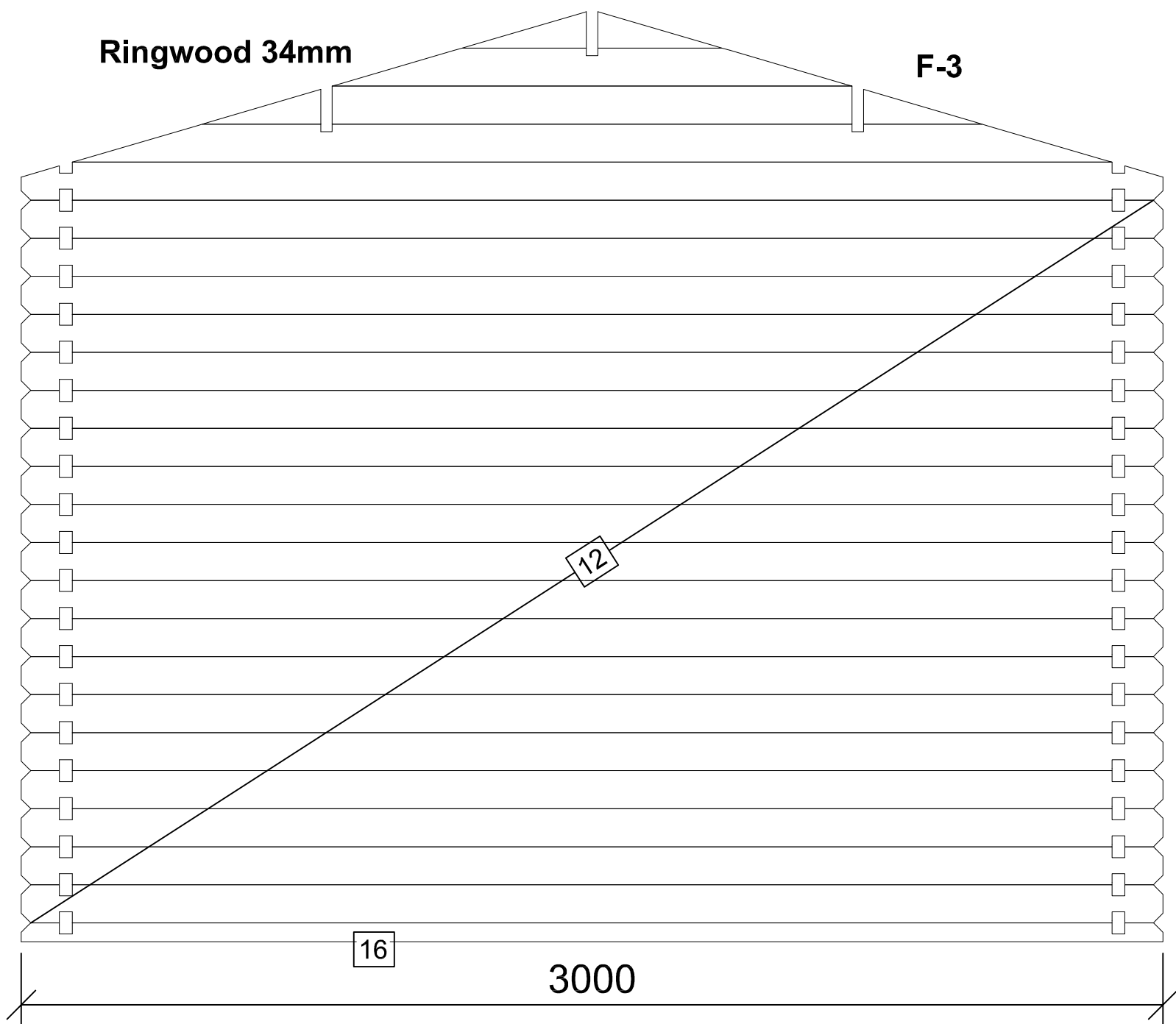
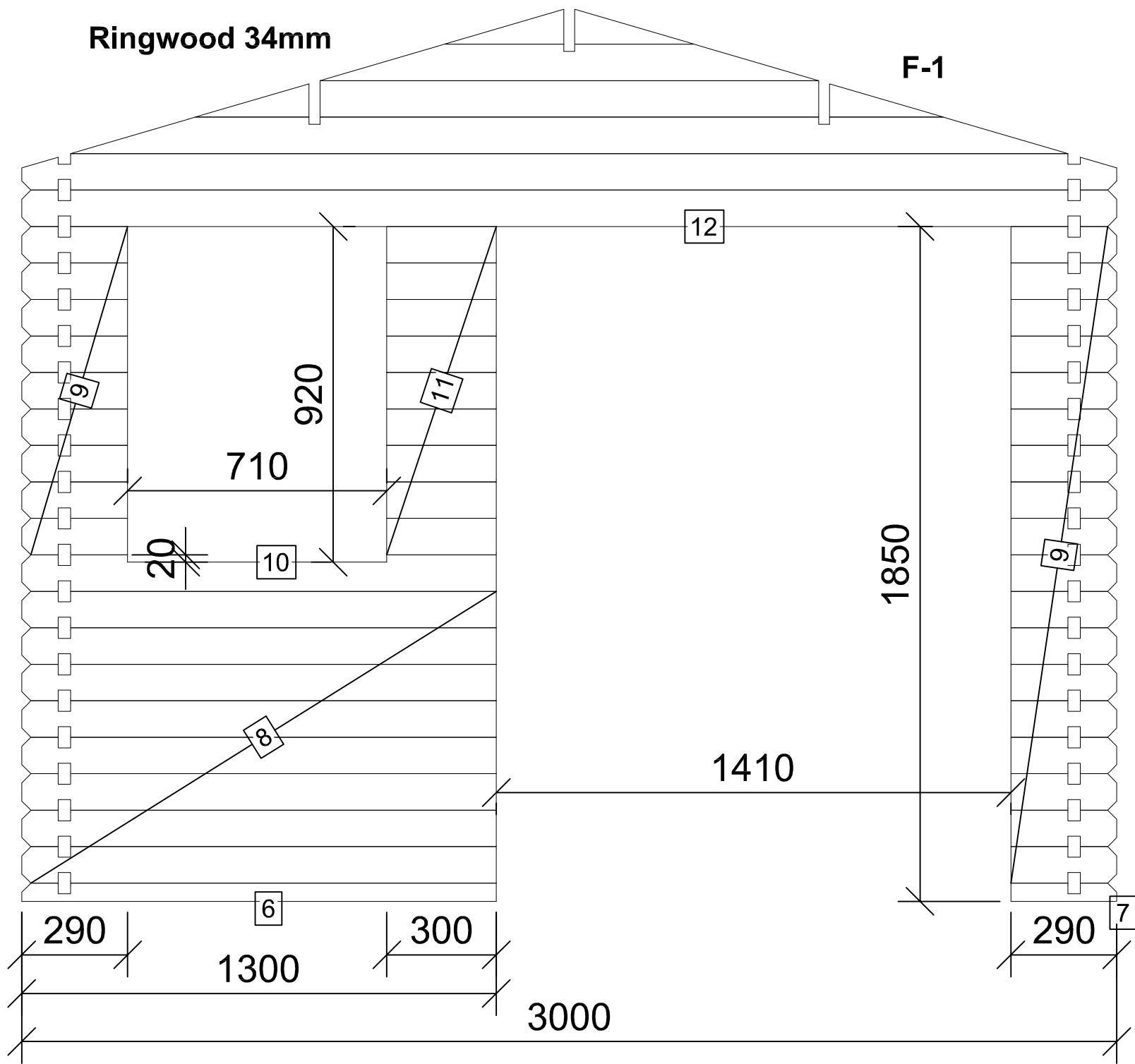

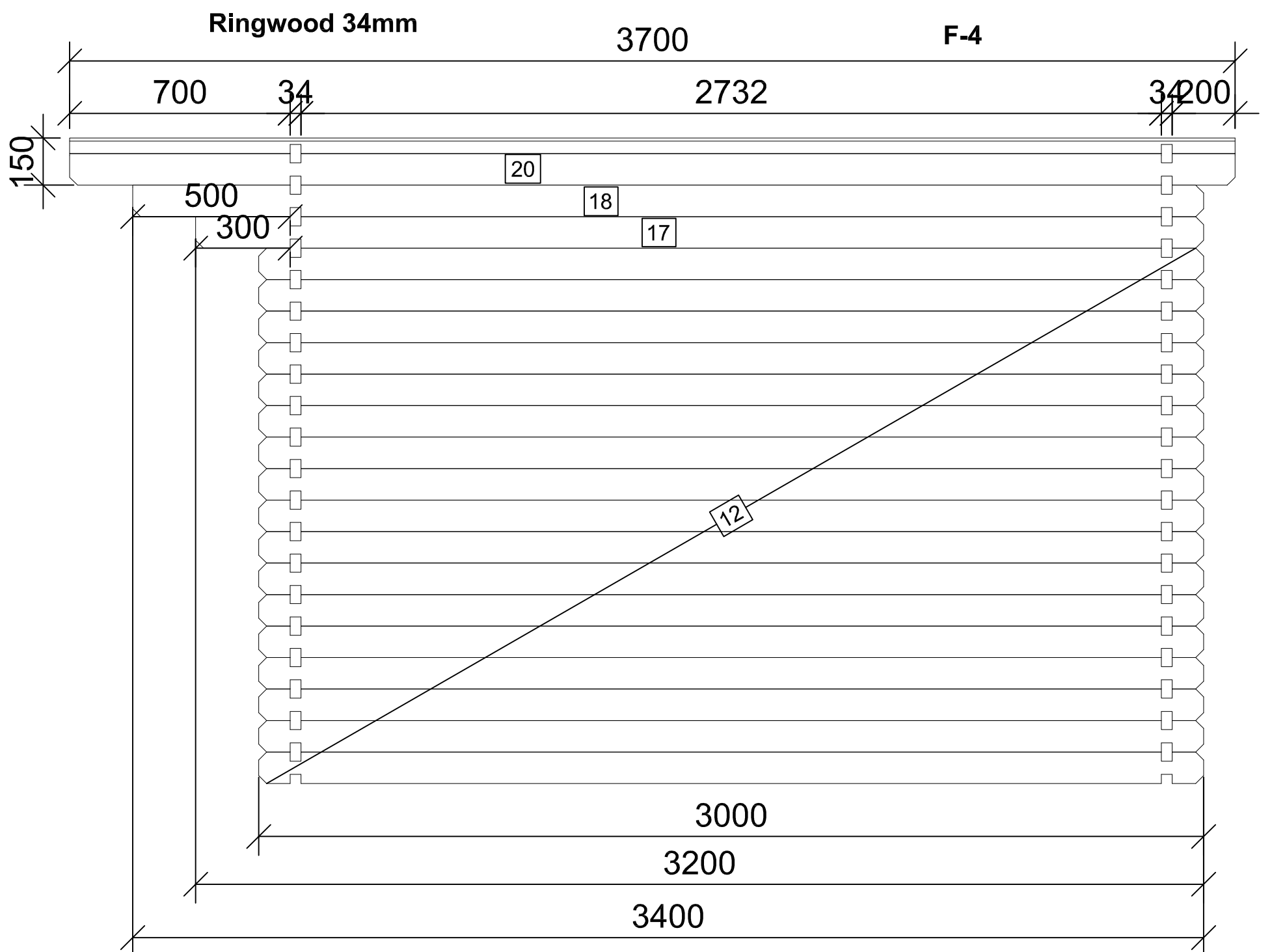
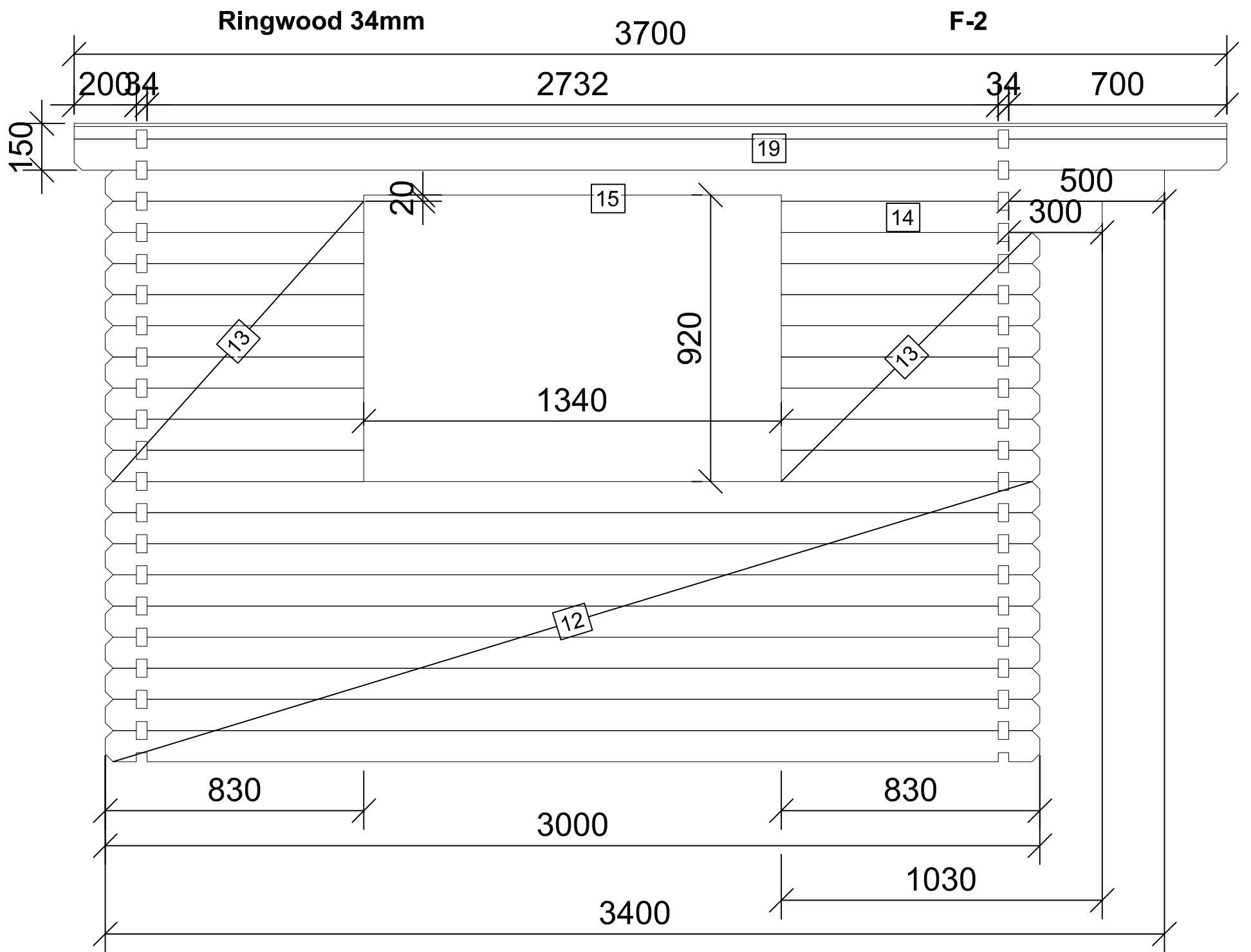

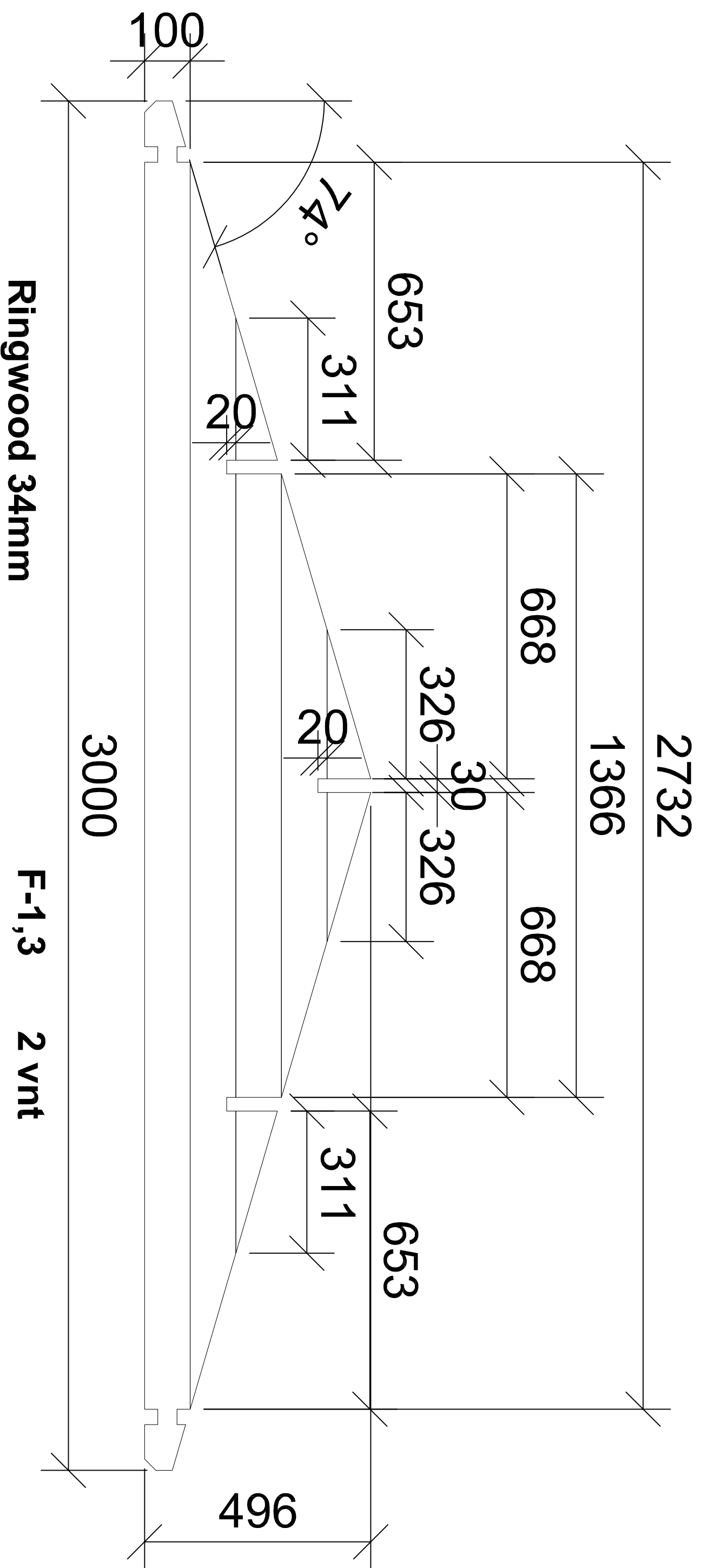

Ringwood 34mm

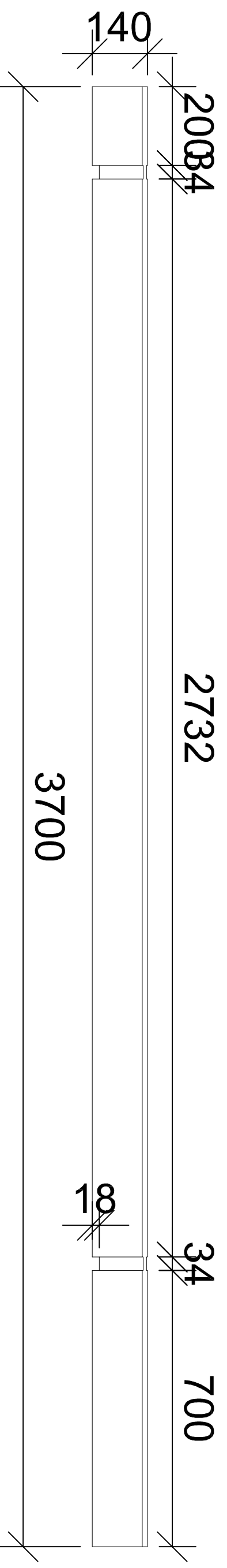
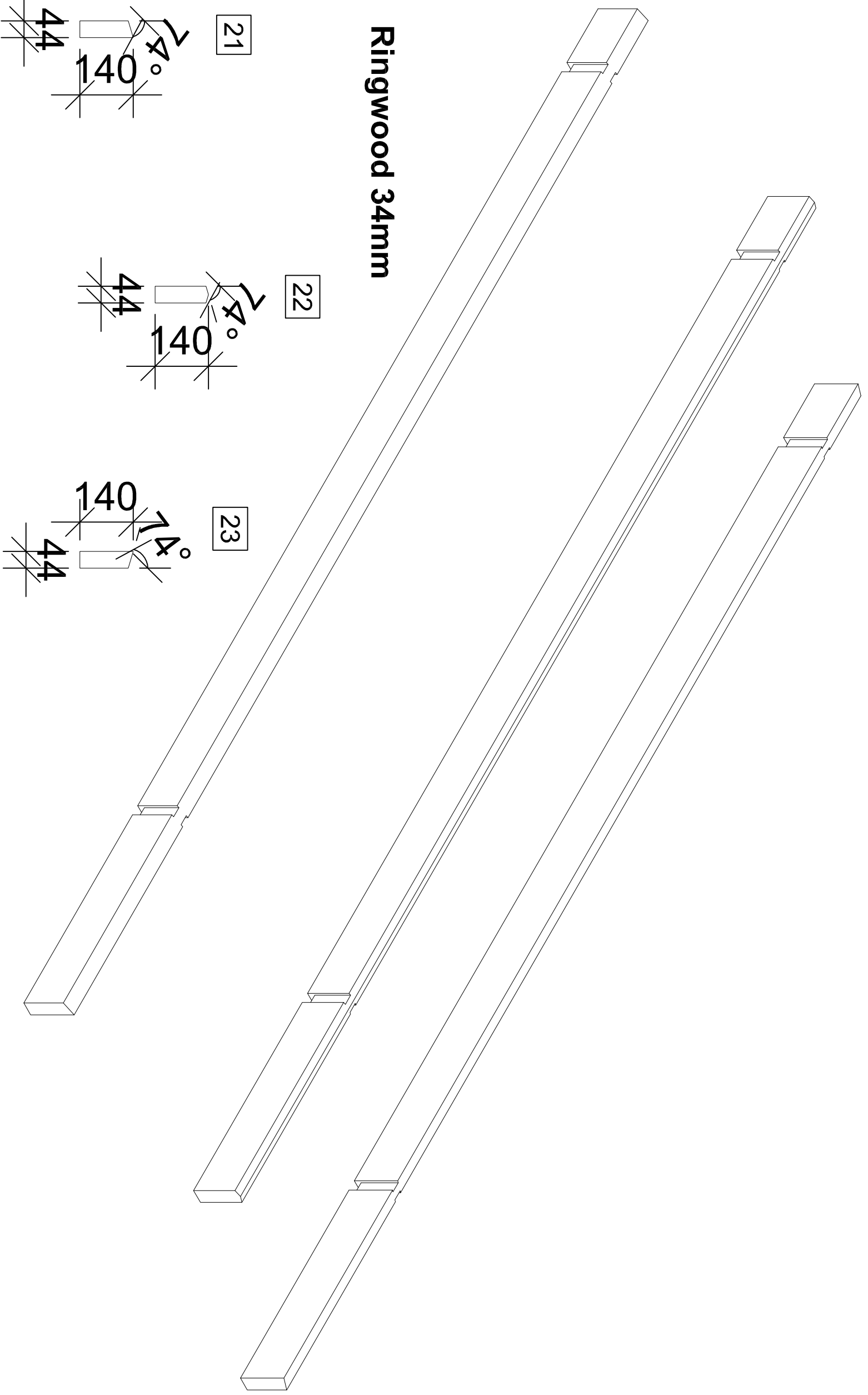

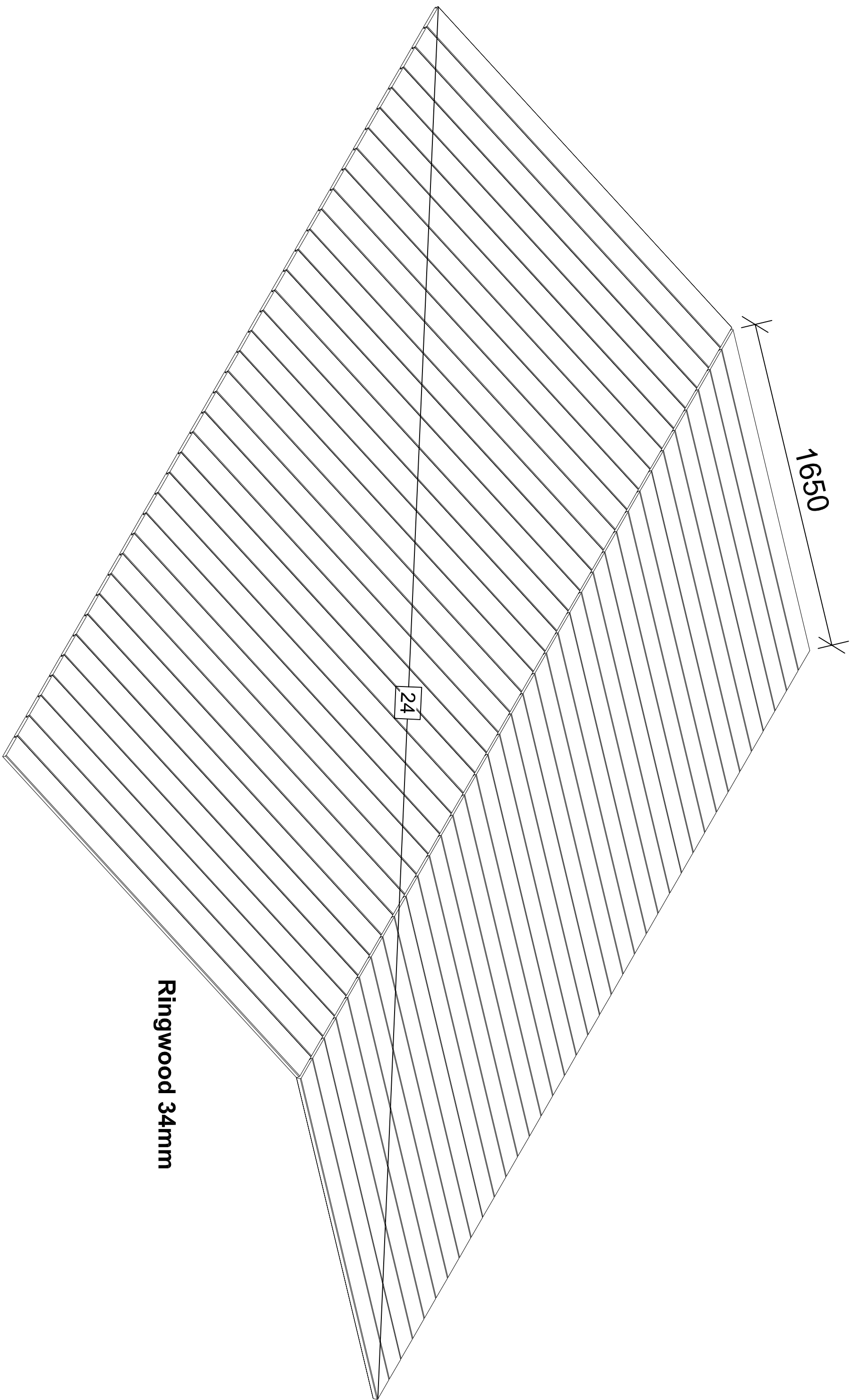

1650

24

Ringwood 34mm

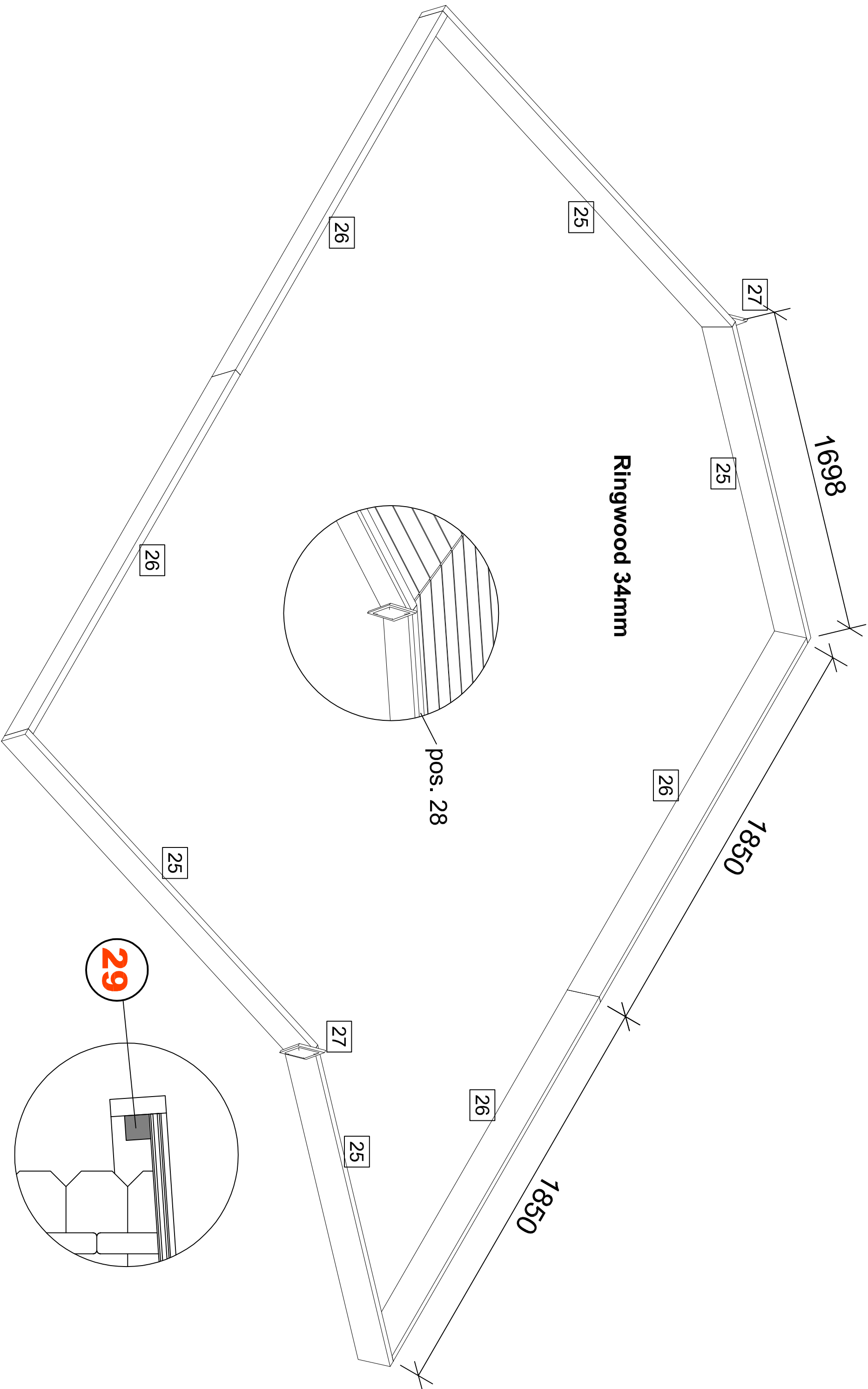

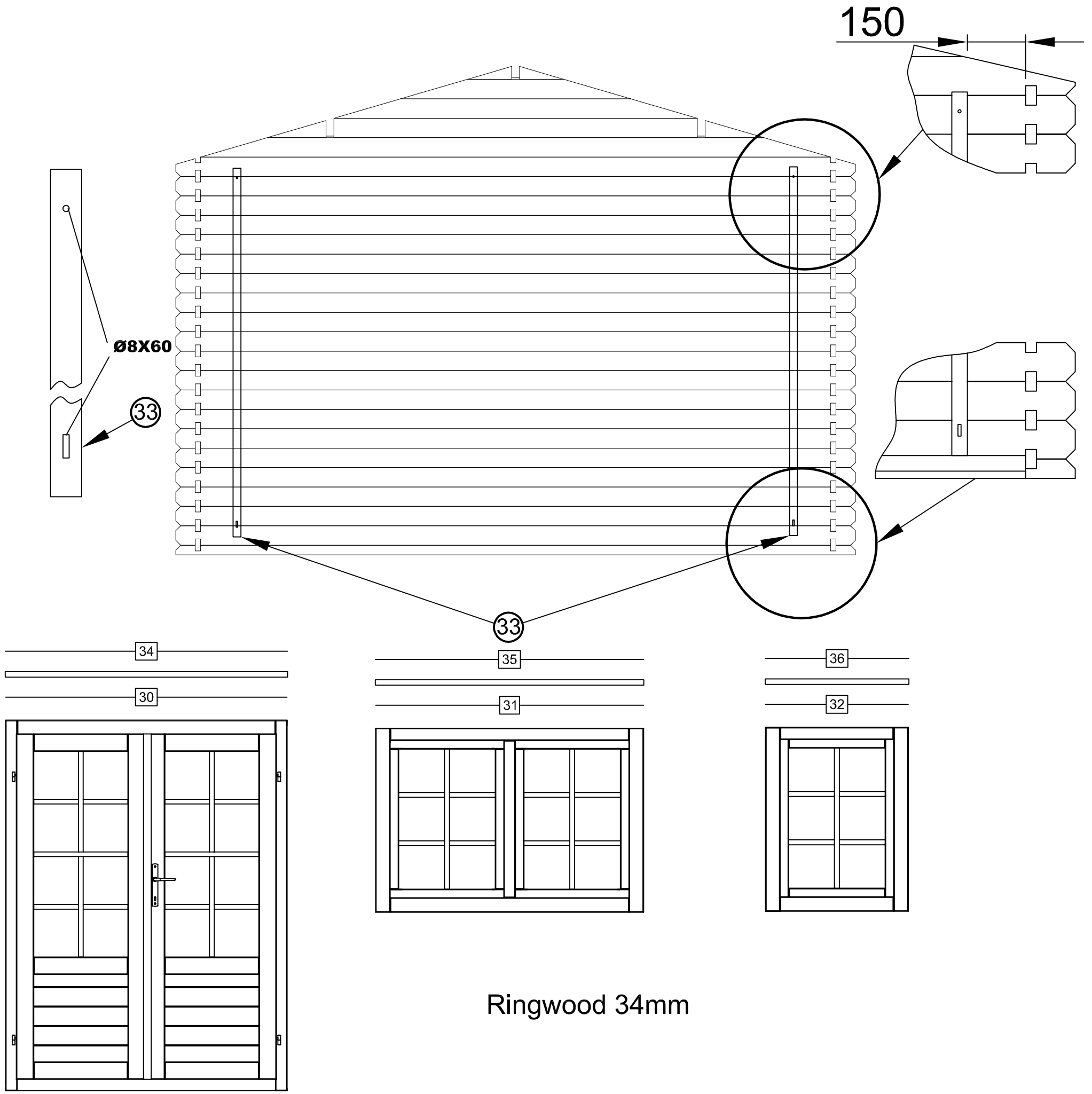

Door and window extra part above is longer
must be cut in the construction site

Ringwood 34mm

300x300 cm

34 mm 2020.12.11

BE 2020

-Date-

Degree <74°

Dimensions, mm

A B C

Pos.

Quantity

		2790	40	70	1	2
		2650	40	70	2	2
		2650	40	55/60	3	5
		2722	28	100/130	4	$\frac{28}{22} + 1$ extra
			19	40	5	~ 11 m.
		1300	35	50	6	1
		290	35	50	7	1
		1300	35	100	8	8
		290	35	100	9	27
		1300	35	100	10	1
		300	35	100	11	9
		3000	35	100	12	46 + 1 extra
		830	35	100	13	17
		1030	35	100	14	1
		3400	35	100	15	1
		3000	35	50	16	1
		3200	35	100	17	1
		3400	35	100	18	1
		3700	35	150	19	1
		3700	35	150	20	1

-Packing No.-

-Name, last name-

Ringwood 34mm

300x300 cm

34 mm 2020.12.11

BE 2020

-Date-

Degree <74°

Dimensions, mm

Pos.

Quantity

A

B

C

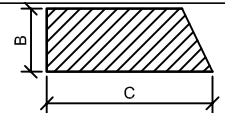

3700

44

140

21

1

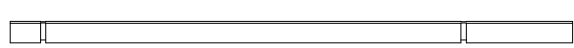
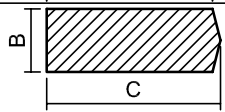

3700

44

140

22

1

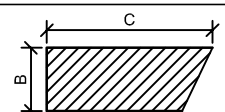

3700

44

140

23

1

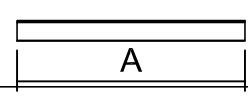
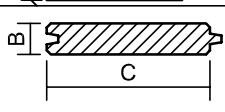

1650

19

$\frac{100}{86}$

24

$\frac{74}{87}$ +1 extra

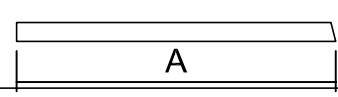
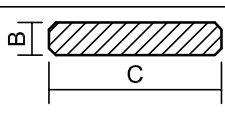

1698

28

130

25

4

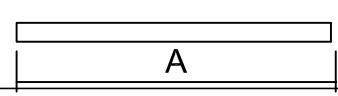
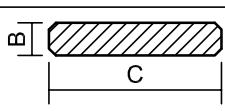

1850

28

130

26

4

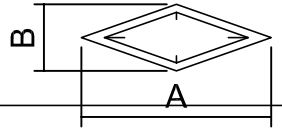

200

70

27

2

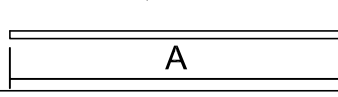
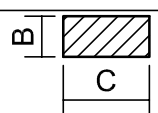

1698

19

40

28

4

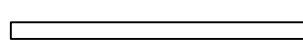
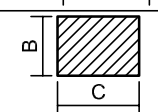

1850

40

40

29

4

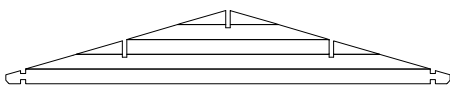

3000

496

F-1,3

2

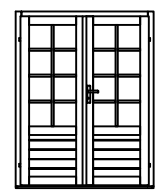

1410

1850

30

1

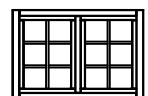

1340

920

31

1

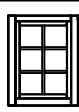

710

920

32

1

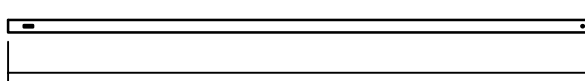
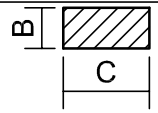

1880

19

40

33

4

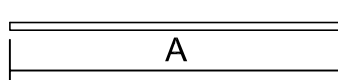
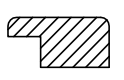

1510

28

45

34

1

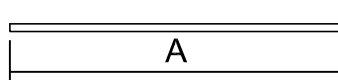
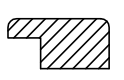

1440

28

45

35

1

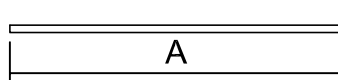
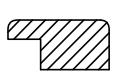

810

28

45

36

1

-Packing No.-

-Name, last name-

Constructor I.Paulauskas

Page 2/2

1 vnt.

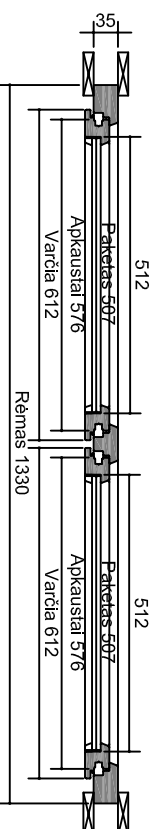
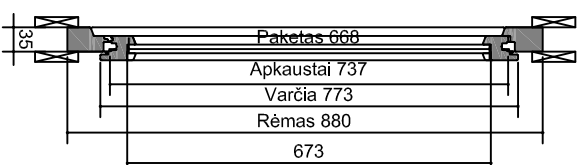
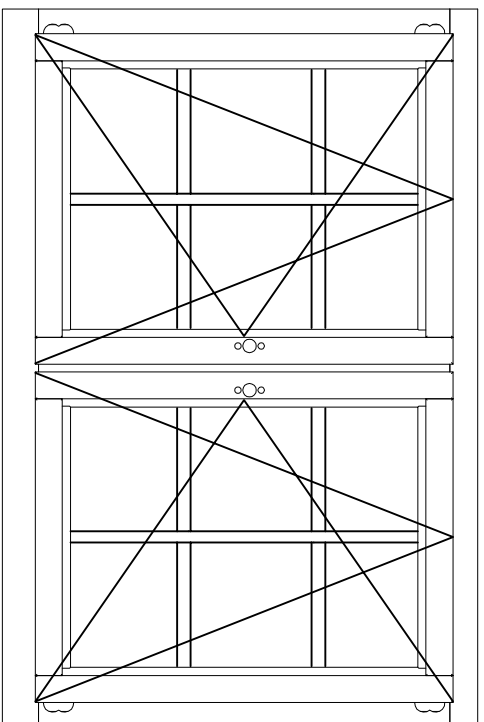

PASTABOS LANGAMS:

- 1. PROFILIS IV45
- 2. FALZ -18, AŠIS -9
- 3. FURNITŪROS SPALVA: RUDA

1 vnt.(D)

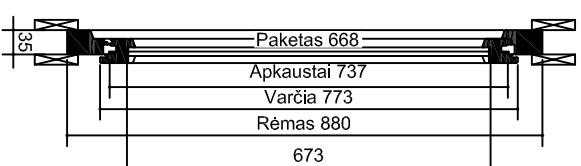
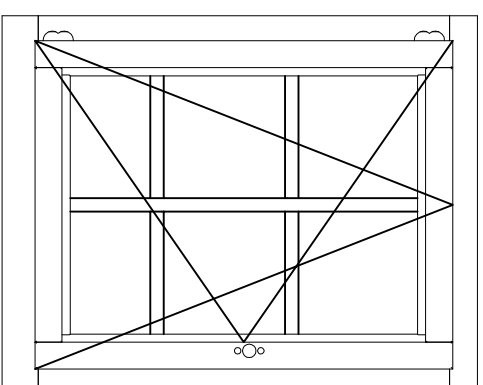

PASTABOS LANGAMS:

- 1. PROFILIS IV45
- 2. FALZ -18, AŠIS -9
- 3. FURNITŪROS SPALVA: RUDA

1 vnt.

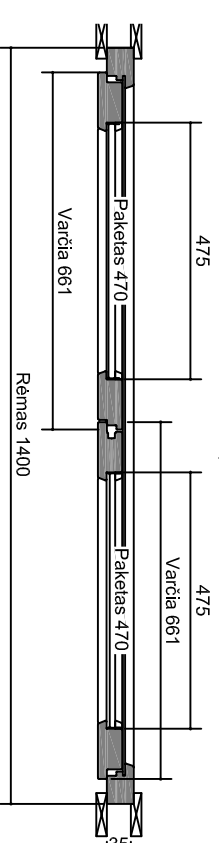
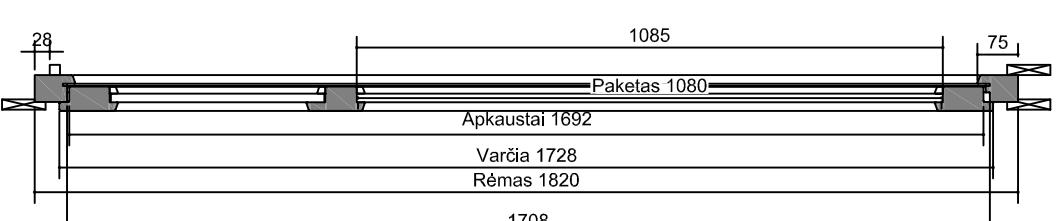
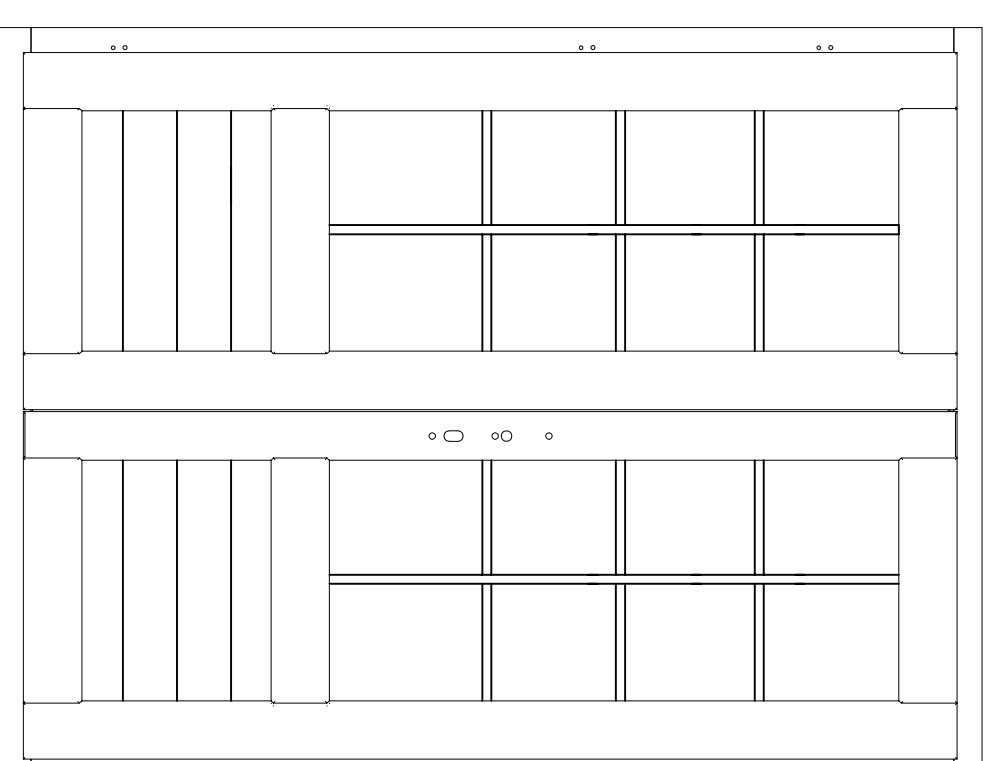

PASTABOS DURIMS:

- 1. PROFILIS IV45
- 2. FALZ -18, AŠIS -9
- 3. FURNITŪROS SPALVA: RUDA

Ringwood 34mm

su frezavimais vyriams